

# OLYMPUS®

---

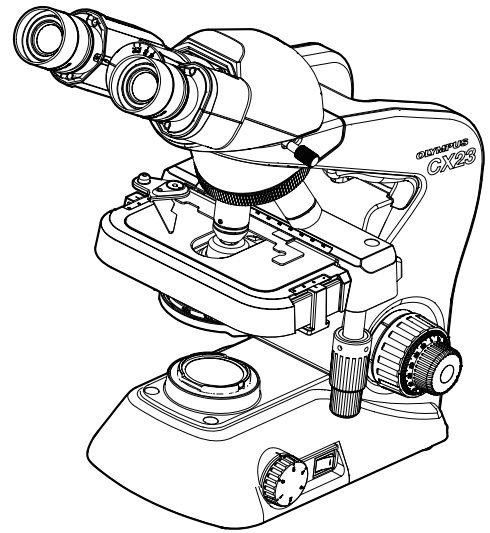

## INSTRUCTIONS

---

# CX23

## Biological microscope

CE

This instruction manual is for the Olympus biological microscopes model CX23. To ensure the safety, obtain optimum performance and to familiarize yourself fully with the use of this microscope, we recommend that you study this manual thoroughly before operating the microscope. Retain this instruction manual in an easily accessible place near the work desk for future reference.

AX8490

**NOTE:** This equipment has been tested and found to comply with the limits for a Class A digital device, pursuant to Part 15 of the FCC Rules. These limits are designed to provide reasonable protection against harmful interference when the equipment is operated in a commercial environment. This equipment generates, uses, and can radiate radio frequency energy and, if not installed and used in accordance with the instruction manual, may cause harmful interference to radio communications. Operation of this equipment in a residential area is likely to cause harmful interference in which case the user will be required to correct the interference at his own expense.

**FCC WARNING:** Changes or modifications not expressly approved by the party responsible for compliance could void the user's authority to operate the equipment.



In accordance with European Directive 2002/96/EC on Waste Electrical and Electronic Equipment, this symbol indicates that the product must not be disposed of as unsorted municipal waste, but should be collected separately.

Refer to your local Olympus distributor in EU for return and/or collection systems available in your country.

**For Korea only**

B급 기기 (가정용 방송통신기자재)

이 기기는 가정용(B급) 전자파적합기기로서 주로 가정에서 사용하는 것을 목적으로 하며, 모든 지역에서 사용할 수 있습니다.

# Contents

<b>Safety precautions</b> .....	<b>1</b>
⚠ CAUTION - Prevention of infection - .....	1
⚠ CAUTION - Installation of the device - .....	1
⚠ CAUTION - Electrical safety - .....	2
⚠ CAUTION - LED (light emitting diode) - .....	2
⚠ CAUTION -Safety symbols- .....	2
Intended use.....	3
Handling precautions .....	3
Maintenance and storage .....	4
<b>1 Standard combination</b> .....	<b>5</b>
<b>2 Nomenclature of operating portions</b> .....	<b>6</b>
<b>3 Summary of brightfield observation procedure</b> .....	<b>7</b>
<b>4 Detailed observation procedure</b> .....	<b>8</b>
<b>1</b> Turning the LED Illumination ON .....	8
<b>2</b> Placing specimen on the stage.....	8
<b>3</b> Adjusting the focus .....	9
<b>4</b> Adjusting the interpupillary distance.....	10
<b>5</b> Adjusting the condenser position and aperture iris diaphragm .....	10

6	Adjusting the diopter .....	11
7	Switching the objectives.....	12
8	Using the 100X oil immersion objective .....	13
<b>5 Useful Information.....</b>		<b>14</b>
<b>6 Troubleshooting .....</b>		<b>16</b>
<b>7 Specifications.....</b>		<b>18</b>
<b>8 Optical characteristics .....</b>		<b>19</b>
<b>9 Assembly.....</b>		<b>20</b>
<b>10 Optional accessories .....</b>		<b>21</b>
10-1 System diagram of optional accessories .....		21
10-2 Installation and operation of optional accessories.....		21
1	Filter holder CH2-FH and darkfield ring CH2-DS.....	21
2	Eyepieces WHSZ15X-H.....	22
3	Mounting the eyepiece micrometer (optional) .....	22
4	Reflection mirror CH20-MM.....	23
5	Storing in wooden case (optional).....	23
■	Proper selection of the power supply cord.....	24

## Safety precautions

If the product is used in a manner not specified by this manual, the safety of the user may be imperiled. In addition, the product may also be damaged. Always use the product as outlined in this instruction manual.

The following symbols are used in this instruction manual.

 **CAUTION** : Indicates a potentially hazardous situation which, if not avoided, may result in minor or moderate injury.

 **CAUTION** : Indicates a potentially hazardous situation which, if not avoided, may result in damage to the equipment or other property.

⊙ : Indicates commentary (for ease of operation and maintenance).

### CAUTION - Prevention of infection -

**Wear protective equipment such as gloves, etc.**

When you observe the specimens which have potentiality of infection, wear protective equipment such as gloves, etc. to prevent the specimens from touching your skin directly.

When you maintain the device which may have contacted the specimens which have potentiality of infection, wear protective equipment such as gloves, etc., or clean the device before operation.

**After observation, clean the portions where specimens contacted directly.**

**Remove the specimen when moving the device.**

When moving this device, be sure to remove the specimen first, since it is in danger of dropping and spattering.

**In case the specimen is damaged, promptly take the infection prevention measures.**

**When disposing of the device, follow the regulations and rules of your local government.**

When disposing of the device which contacted the specimens which have potentiality of infection, follow the regulations and rules of your local government,

### CAUTION - Installation of the device -

**Install the microscope on a sturdy, level table or bench.**

For safety in particular, do not place a mat, etc. under the device.

## CAUTION - Electrical safety -

### **Always use the AC adapter and power cord provided by Olympus.**

If the proper AC adapter and power cord are not used, the electric safety and EMC (Electro-Magnetic Compatibility) performance of the device can not be assured. If no power cord is provided, please select the proper power cord by referring to the section "Proper selection of the power supply cord" at the end of this instruction manual.

### **Ground the device.**

Connect the ground terminal of the power cord and that of the power outlet. If the device is not grounded, our intended electric safety and EMC performance of the device can not be assured.

### **Do not use the device in close proximity to the sources of strong electromagnetic radiation.**

Proper operation may be interfered. The electromagnetic environment should be evaluated prior to operation of the device.

### **Remove the power cord in case of emergency.**

Install the product at a location where you can reach the power cord connector or the power outlet at hand to remove the power cord quickly.

This device complies with the emission and immunity requirements described in IEC61326 series.



## CAUTION - LED (light emitting diode) -

### **Do not directly look at the light from the LED unit for a long time.**

If you feel that the light from LED units is too bright during observation, adjust the intensity using the brightness adjustment knob and continue observation. The LED built in this product is basically eye-safe. However, direct viewing the light from the LED unit for extended time in the state you feel dazzling may cause damage to the eyes.

## CAUTION -Safety symbols-

The following symbols are found on the microscope. Study the meaning of the symbols and always use the equipment in the safest possible manner.

Symbol	Explanation
	Indicates a non-specific general hazard. Follow the description given after this symbol or in the instruction manual.
	Indicates that the main switch is ON.
	Indicates that the main switch is OFF.

## Intended use

This product has been designed to be used to observe magnified images of specimens in various routine work and research applications.

This includes the observation of living cells or of specimen taken from tissues to gain physiological or morphological information at hospitals or laboratories. Typical field of applications are genetics, human blood and tissue examination, neurology, pharmacology and cellular biology.

Do not use this instrument for any purpose other than its intended use.



This product complies with the requirements of directive 98/79/EC concerning in vitro diagnostic medical devices. CE marking means the conformity to the directive.

## Handling precautions

- CAUTION** • This microscope is a precision instrument. Handle it with care and avoid subjecting it to a sudden or severe impact.
- Never disassemble any part of the product. Otherwise, failure could be caused.

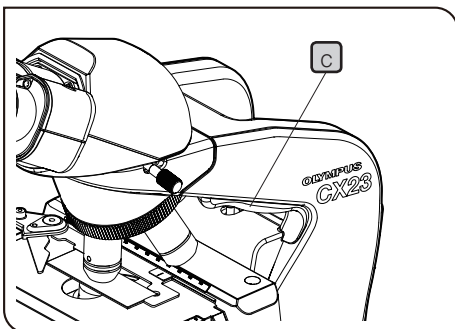
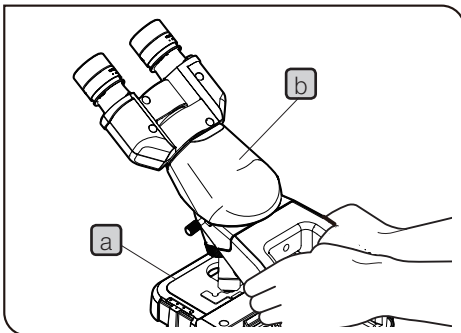

1. Handle the microscope with care when you carry it, and avoid subjecting it to severe impact or dirt.
2. Do not use the microscope where it is subjected to direct sunlight, high temperature and humidity, dust or vibrations. (For the conditions of operating environments, see "7 Specifications" (p.18))
3. Make sure to adjust the rotation tension of the coarse adjustment knob with the tension adjustment ring. Please refer to page 9 for the adjustment method.
4. When installing the microscope, be sure to leave enough space around the AC adapter if the AC adapter is not stored in the microscope.
5. When carrying this microscope, remove the AC adapter or store the AC adapter and the power cords into the microscope. Then, hold both sides of the arm hole as shown in the picture on the left and carry the microscope carefully. It is easier to hold the arm hole by putting the ball of your fingers at the finger contact area **c** shown in the picture on the left. For procedures to store the AC adapter and the power cords, refer to "9 Assembly" (p.20).

- CAUTION** • Do not hold the stage **a** or observation tube **b**, since they may be damaged. Also, when you carry the microscope, remove specimens or filters in advance. Otherwise, they may be dropped.

- When carrying the microscope, be careful not to hit the output connector of the AC adapter. The AC adapter or the microscope may be damaged.

- When carrying the microscope, be careful not to touch the objective.

## Maintenance and storage

1. Do not leave stains or fingerprints on the lenses and filters. If they get dirty, blow away dust with a commercially available blower and gently wipe the lens or filter with a piece of cleaning paper (or clean gauze). For cleaning fingerprints and oil stains, slightly moisten a piece of cleaning paper with commercially available absolute alcohol and wipe them off with it.

**CAUTION** Since the absolute alcohol is highly flammable, it must be handled carefully. Be sure to keep it away from open flames or potential sources of electrical sparks. For example, electrical equipment that is being switched on or off could cause ignition of a fire. Also remember to always use absolute alcohol only in a well-ventilated room.

2. Use a diluted neutral detergent to clean the parts other than the glass components. Moisten a soft cloth with diluted neutral detergent and wipe the surfaces of the parts. Do not use organic solvents to clean the parts other than the glass components, since it deteriorates painted surfaces or plastic parts.
3. When not using the product, store it in a dry place or cover it with a dust cover. Please purchase the dedicated dust cover (made by Olympus) at the sales office.

**CAUTION** Do not use a cover with a high sealing performance, e.g. plastic bags, etc. as a dust cover. The humidity inside the microscope may rise and may be damaged.

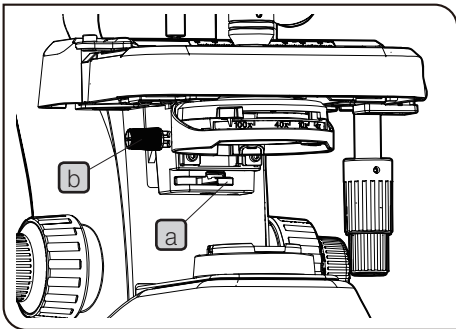

4. When cleaning the condenser, move the lever **a** to the left end, lower the condenser with the condenser up/down knob **b**, and remove the condenser. Then, clean the upper lens area. When attaching the condenser, engage the condenser to the condenser attaching part and push the engaged part upward until it touches the top.

**CAUTION** This condenser is not compatible with other microscopes. Do not use this condenser with other microscopes.

5. When disposing of this product, be sure to follow the regulations and rules of your local government. For any question, contact the sales office you have purchased this product.



# 1 Standard combination

☉ Refer to the drawing below and make sure that all necessary components are included in the product you purchased.

**CAUTION** The objectives have been screwed in tightly to prevent them from being loosened during transportation. To remove an objective, turn it counterclockwise while holding it with a rubber sheet, etc., so that your fingers don't slip.

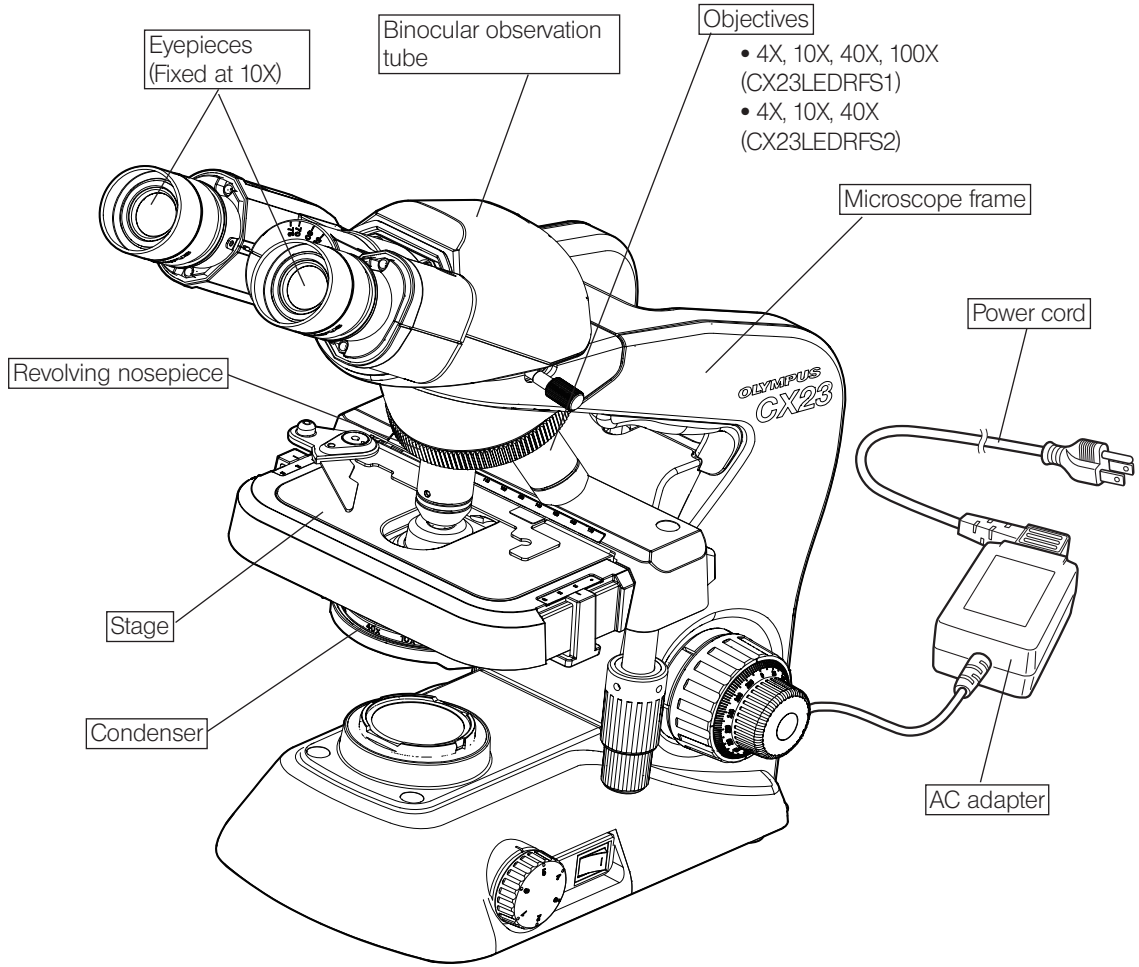

● Optional accessories

• Filter Holder  
CH2-FH



• Eyepieces  
WHSZ15X-H

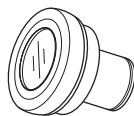

• Darkfield ring  
CH2-DS



• Reflection mirror  
CH2-MM

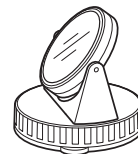

- Objective 100X
- Wooden case : CH20-WB2
- Eyepiece micrometer : diameter 24 mm, pitch 1.5 mm

# 2 Nomenclature of operating portions

## Cautions when unpacking

◎ The items 1 to 3 described below have been attached at the factory to prevent quality deterioration during transportation. Remove these items from the products. However, do not dispose them of and keep them for future transportation. Loosen the observation tube clamping knob and turn the observation tube so that the eyepieces come to the same direction as shown in the illustration below.

1. Revolving nosepiece / Observation tube clamping knob.
2. Stage/sample holder protection sheet.
3. Protection pad under the stage.

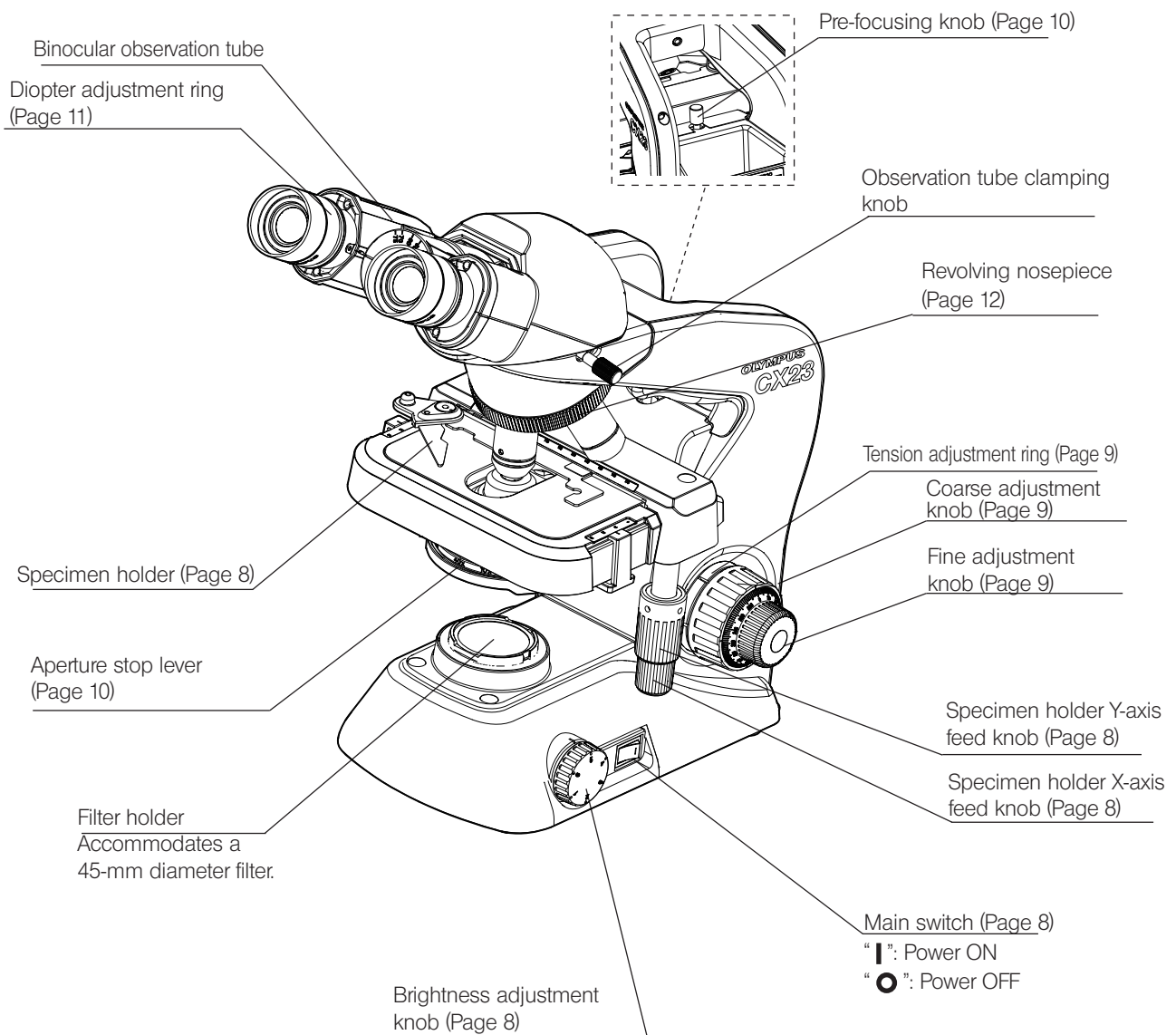

◎ Attach the AC adapter and power cord as described in chapter 9, "Assembly" on page 20".

◎ For detailed explanation of each operation portion, refer to the page indicated inside parentheses.

# 3 Summary of brightfield observation procedure

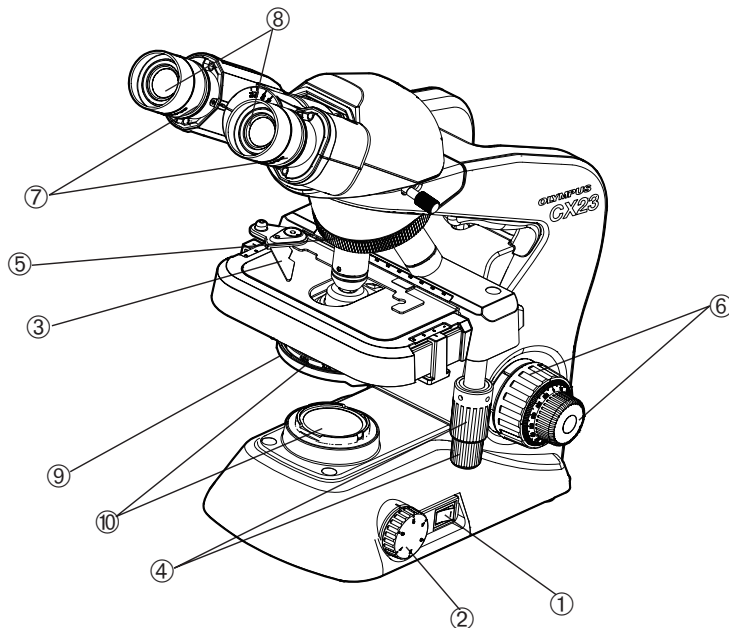
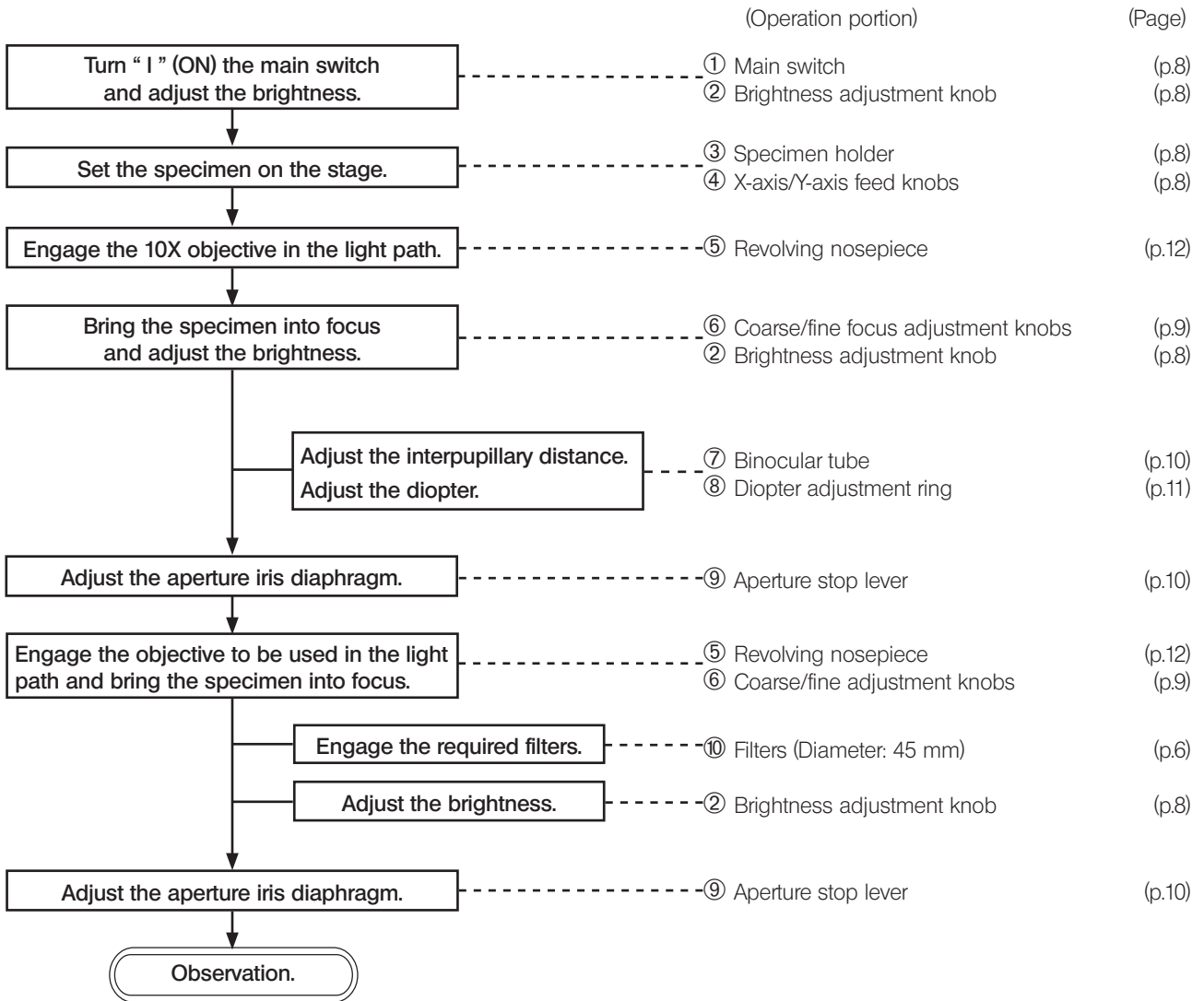

# 4 Detailed observation procedure

## 1 Turning the LED Illumination ON

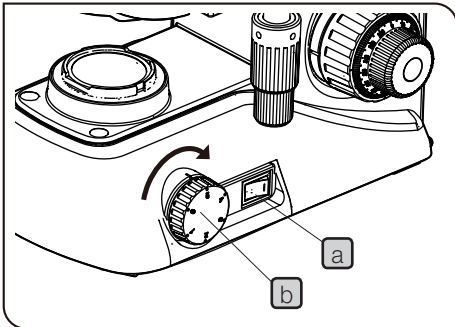

- 1 Set the main switch **a** to "I" (ON).
- 2 Rotating the brightness adjustment knob **b** in the direction of the arrow increases brightness and rotating it in the opposite direction decreases brightness. The figures around the knob represent rough indication of the brightness.

## 2 Placing specimen on the stage

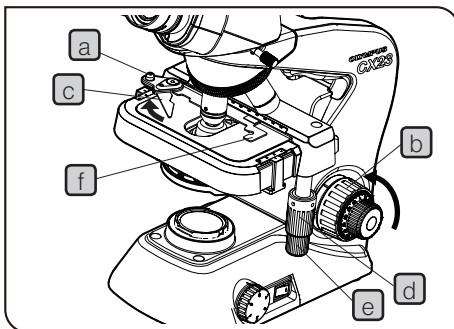

**CAUTION** If the specimen holding lever **c** is returned with a strong force or the knob **a** of the specimen holding lever **c** is released in the middle, the slide glass may break.

- 1 Rotate the coarse adjustment knob **b** in the direction of the arrow to fully lower the stage.
- 2 Open the specimen holding lever **c** of the specimen holder in the direction of the arrow, set the specimen by sliding it on the stage from the front toward the rear.
- 3 After setting the specimen, return the specimen holding lever **c** gently.
- 4 Rotating the upper Y-axis knob **d** moves the specimen in the Y-axis direction and rotating lower X-axis knob **e** moves the specimen in the X-axis direction.

**CAUTION** • Do not move the specimen by holding the specimen holder **f** directly by hand, since it will damage the rotary mechanism of the Y-axis and X-axis knobs.

- When movement of the specimen reaches the limits of Y-axis and X-axis movement range, respective rotation tensions of Y-axis and X-axis knobs become heavy. Stop rotating the knobs in that case.

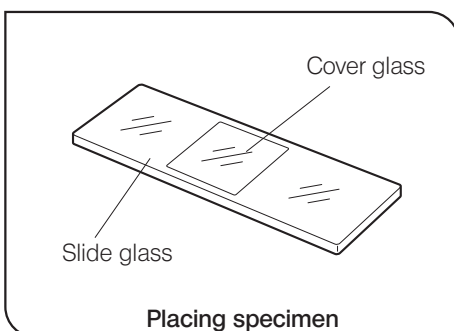

**Cover glass**

To allow the objective to bring out its full performance, use the cover glass with a thickness of 0.17 mm.

**Slide glass**

It is recommended to use the slide glass with a length of 76 mm, width of 26 mm and thickness between 0.9 and 1.4 mm.

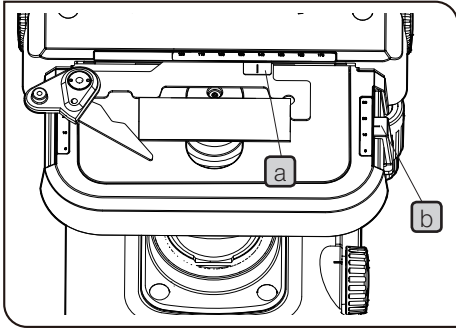

**Specimen position scale**

- ◎ By reading and taking a note of the X-axis and Y-axis scales (coordinates), the original position once observed in the specimen can be retrieved even after the movement of the specimen.
- 1** The X-axis scale should be read at the position **a** on the specimen holder.
- 2** The Y-axis scale should be read at the position of index line **b**.

**3 Adjusting the focus**

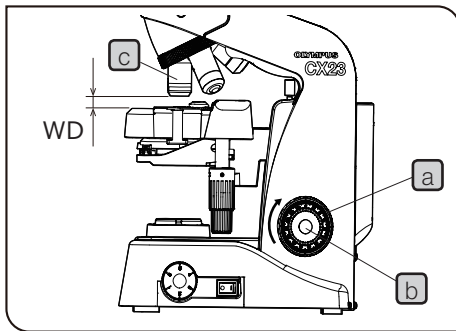

**Adjust the focus**

- 1** Face to the microscope from the side and rotate the coarse adjustment knob **a** in the direction of the arrow so that the objective **c** is as close as possible to the specimen.
- 2** While observing the specimen through the eyepieces, slowly rotate the coarse adjustment knob **a** in the opposite direction to the arrow to lower the stage, and adjust to the appropriate brightness.
- 3** When the specimen comes into view, rotate the fine adjustment knob **b** to obtain the precise focus.

**Working distance (WD)**

◎ The WD means the distance between the objective and the specimen when precise focus of the specimen is obtained.

<b>Objective magnification</b>	4X	10X	40X	100X
<b>WD (mm)</b>	278	8.0	0.6	0.13

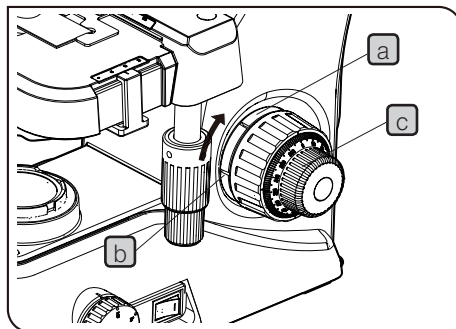

**Adjusting the tension of the coarse adjustment knob**

- 1** The tension of the coarse focus adjustment knob can be adjusted. Insert the tip of a large flat-blade screwdriver into the groove **b** on the tension adjustment ring **a** and rotate the ring.  
  
Rotating it clockwise (in the direction of the arrow) increases the tension and counterclockwise decreases the tension.
- 2** If the stage descends by its own weight or the focus obtained with the fine adjustment knob **c** is lost soon, the tension is set too loose. In this case, turn the tension adjustment ring **a** in the direction of the arrow to increase the tension.

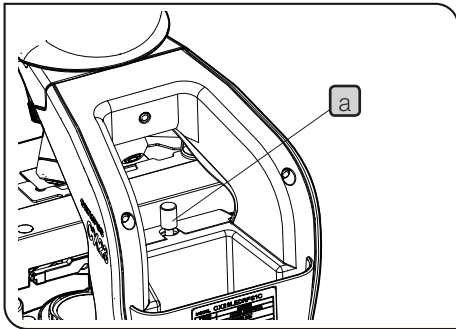

#### Using the pre-focusing knob

⊙ The pre-focusing knob prevents breakage of the specimen by collision between the specimen and objective.

**1** After bringing the specimen into focus with the objective which has the shortest WD, rotate the pre-focusing knob **a** so that bottom of the pre-focusing knob touches the stage guide.

**2** To provide a certain margin of focusing range, rotate the knob by about half turn backward from the stopped position.

**CAUTION** Basically, it is recommended to always use the pre-focusing knob **a** but if it is not necessary, set the pre-focusing knob at the highest position. If the pre-focusing knob **a** is not set at the highest position, the specimen may not be focused.

#### 4 Adjusting the interpupillary distance

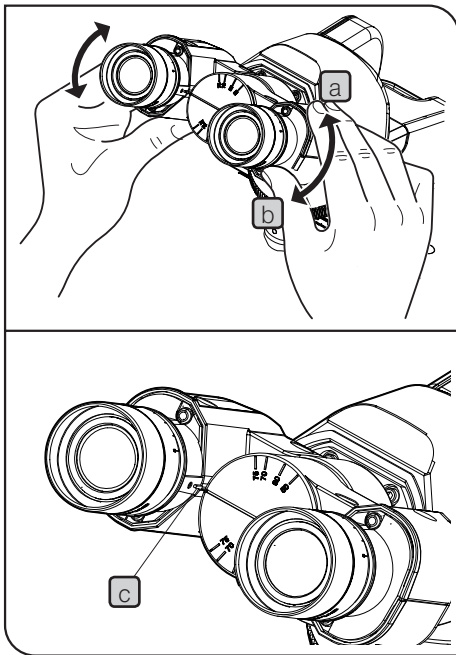

⊙ The interpupillary distance adjustment is to adjust the distance between two eyepieces according to that between your eyes. This helps to observe a single microscopic image and to reduce eye strain during observation.

While keeping the right and left eyepieces horizontally, move the binocular portion in the **a** or **b** direction to coincide the right view field with the left completely. The value indicated by the index (protrusion) **c** of the left eyepiece sleeve represents the interpupillary distance.

⊙ Note your interpupillary distance so that it can be quickly duplicated.

⊙ You can move the eyepieces upward and downward from the position where both eyepieces are in a straight line with maximum interpupillary distance.

#### 5 Adjusting the condenser position and aperture iris diaphragm

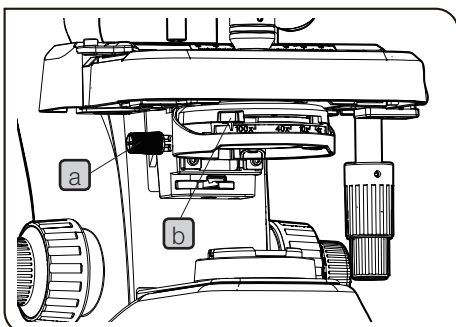

⊙ The condenser is usually used in the highest position. If the entire observed field of view is not bright enough, brightness may be improved by lowering the condenser slightly.

**1** Rotate the condenser height adjustment knob **a** to move the condenser to the highest position.

**2** The aperture stop lever **b** has an indication of objective magnification (4X, 10X, 40X, 100X). Rotate the aperture stop lever so that the indication of the magnification is the same as the objective in use faces front.

## 6 Adjusting the diopter

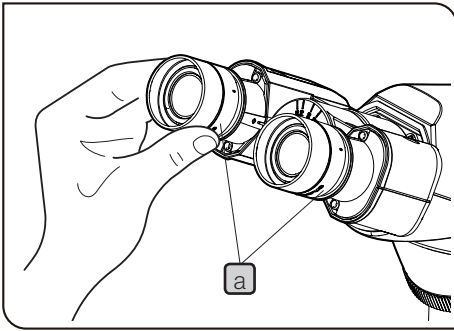

◎ The diopter adjustment is to compensate for the difference of eyesights between left and right eyes of the observer.

When the eyepiece is not equipped with the eyepiece micrometer

- 1 Rotate the diopter adjustment ring **a** at the upper area of the eyepiece to adjust the reticle to [-1] (both sides).
- 2 Adjust the interpupillary distance of the eyepiece so that the observation can be performed with both eyes.
- 3 Place the specimen.
- 4 Engage the 10x objective lens into the light path and rotate the coarse/fine adjustment knob to bring the specimen into focus.
- 5 Change the objective lens to 40x objective lens, and rotate the coarse/fine adjustment knob to bring the specimen into focus.
- 6 Change the objective lens to 10x objective lens. While looking into the right eyepiece with your right eye, rotate the diopter adjustment ring to bring the specimen into focus. In the same manner, while looking into the left eyepiece with your left eye, rotate the diopter adjustment ring to bring the specimen into focus.
- 7 Change the objective lens to 40x objective lens again, and rotate the coarse/fine adjustment knob to bring the specimen into focus.
- 8 Change the objective lens to 10x objective lens, and confirm that the right and left eyepieces are focused on the specimen.
- 9 If the specimen is not focused, bring the specimen into focus according to the procedure in No.6 and repeat No.7 to 9.

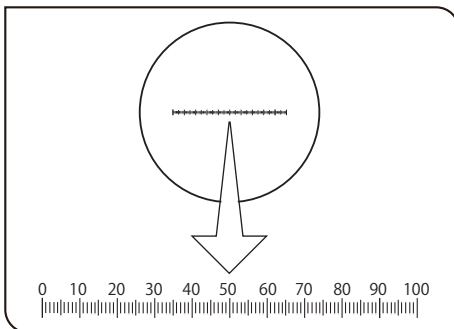

When the eyepiece is equipped with the eyepiece micrometer

- 1 While looking into the eyepiece which is equipped with the eyepiece micrometer, rotate the diopter adjustment ring **a** at the upper area of the eyepiece to adjust so that the scales and lines of the eyepiece micrometer in the view field can be viewed clearly.
- 2 Place the specimen.
- 3 Engage the 10x objective lens into the light path and rotate the coarse/fine adjustment knob to bring the specimen into focus.
- 4 Change the objective lens to 40x objective lens, and rotate the coarse/fine adjustment knob to bring the specimen into focus.
- 5 Change the objective lens to 10x objective lens. Rotate the diopter adjustment ring of the eyepiece which is not equipped with the eyepiece micrometer to bring the specimen into focus. (Leave the eyepiece equipped with the eyepiece micrometer as is.)
- 6 Change the objective lens to 40x objective lens again, and rotate the coarse/fine adjustment knob to bring the specimen into focus.
- 7 Change the objective lens to 10x objective lens, and confirm that the right and left eyepieces are focused on the specimen.
- 8 If the specimen is not focused, bring the specimen into focus according to the procedure in No.5 and repeat No.6 to 8.

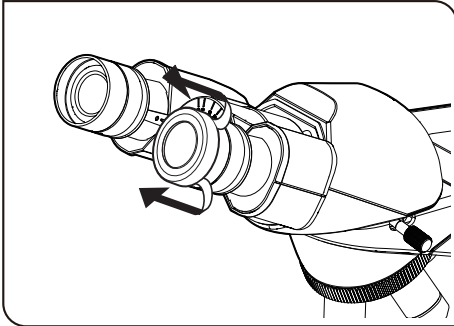

#### Using the eye shades

##### When wearing eyeglasses

Use the eye shades in the normal, folded-down position.

##### When not wearing eyeglasses

Extend the folded eye shades in the direction of the arrow. Observation becomes comfortable, since it prevents extraneous light from entering between the eyepieces and eyes.

## 7 Switching the objectives

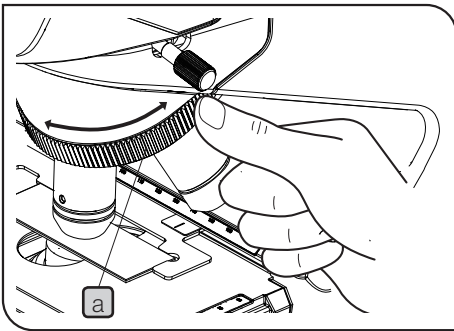

Hold and rotate the revolving nosepiece **a** so that the objective to be used comes exactly above the specimen (specimen slide).

**CAUTION** Do not rotate the revolving nosepiece by holding the objective lens.



## 8 Using the 100X oil immersion objective

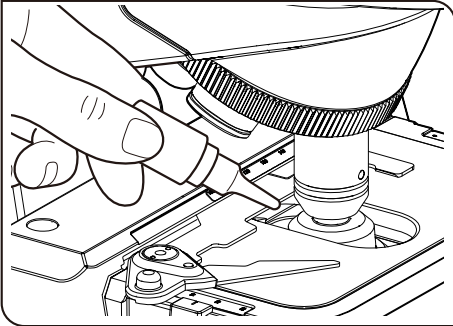

© The designated immersion oil should be applied to the top lens of the 100X oil immersion objective. Otherwise, the observed image will be unable to be focused on.

**CAUTION** Always use the immersion oil supplied by Olympus. If you use immersion oil other than supplied by Olympus, the proper optical performance cannot be demonstrated.

- 1** Bring the specimen into focus using objectives in the order from lower magnification to higher magnification.
- 2** Before engaging the oil immersion objective in the light path, apply a drop of the immersion oil onto the specimen at the area to be observed.
- 3** Rotate the revolving nosepiece to engage the oil immersion objective in the light path and bring the specimen into focus with the fine adjustment knob.

**CAUTION** • If the oil contains air bubbles, the image will be degraded. Make sure that the oil is free of air bubbles.

- To remove bubbles, rotate the revolving nosepiece slightly to move the oil immersion objective by one reciprocation or two.

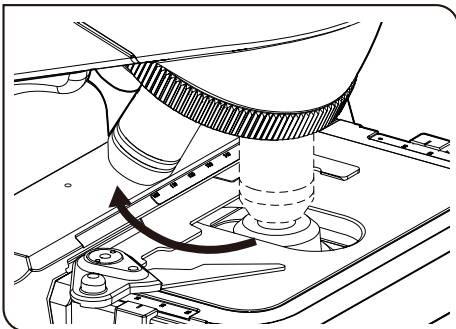

© The condenser of this microscope provides the full performance when oil is placed between the slide glass and the front lens of the condenser. If oil is not applied there, the observation image may become slightly dark.

- 4** After use, lower the stage and rotate the revolving nosepiece for 90 degrees to remove the objective to which the oil is applied. Then, thoroughly wipe off the immersion oil from the front lenses of the objective and the condenser with cleaning paper or gauze slightly moistened with absolute alcohol. Wipe off the immersion oil from the specimen top in the same procedure.

**CAUTION** If the objective is left for some time attached with the immersion oil, the oil is hardened to impede the proper observation.

**CAUTION** • If immersion oil enters your eyes or contacts your skin, immediately take the following treatment.

Eyes: Rinse with fresh water (for 15 minutes or more).

Skin : Rinse with water and soap.

- If the appearance of the eyes or skin is altered or the pain persists, immediately see your doctor.

# 5 Useful Information

## How to track a microscopic image

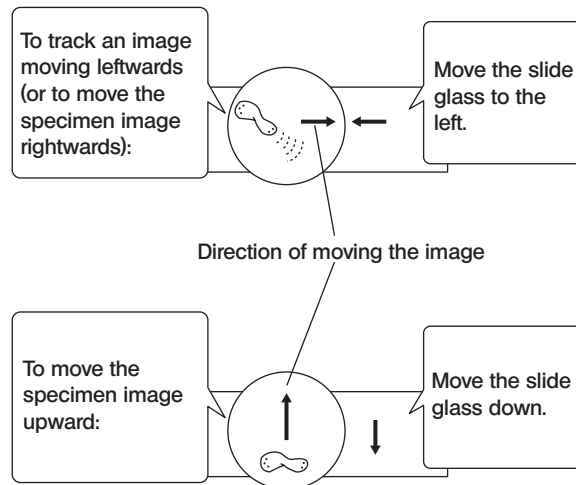

- © The image observed through the microscope moves in directions opposite to the actual up-down and left-right movements of the specimen.

## Total magnification

The size of the specimen image for observation is obtained by multiplying the eyepiece magnification by the objective magnification. This value is referred to as total magnification.

Example: Eyepiece (10X) x Objective (40X) = 400X

## Resolution

Resolution represents how finely a lens is able to distinguish the details of a specimen.

Resolution is mainly determined by the ability of the objective and scarcely related to that of the eyepieces. The function of the eyepieces is to just magnify an image already resolved by the objective.

In case total magnifications are the same, better resolution is obtained with the combinations which have higher magnification of objective.

## Field number (FN)

The field number is the diameter of the image observed through an eyepiece, indicated in millimeters.

Eyepiece 10X : 20 mm WHSZ15X-H:16 mm

## Actual field of view

The actual field of view is the size of the specimen actually observed in the microscope. This makes it possible to find out approximate size of the specimen.

Actual field of view = Field number/Objective magnification

When the eyepiece field number 20 and the objective magnification 10X are used, the actual field of view is equal to:

Actual field of view =  $20/10 = 2.0$  mm

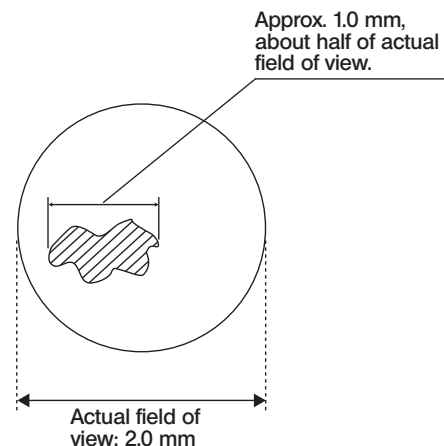

## Aperture stop

The aperture stop of the condenser is a mechanism to adjust the numerical aperture of the condenser to make the incidence angle of the illumination light to the value suitable for observation.

The observation is available with optimum contrast and resolution by adjusting the numerical aperture of the condenser appropriately for the numerical aperture of each objective lens.

In general, since the contrast of the microscope specimen is low, it is appropriate to set the numerical aperture of the condenser to approximately 70 to 80% of the numerical aperture of the objective lens.

The condenser of this product is designed so that the numerical aperture of the condenser is approximately 70% of the numerical aperture of the objective lens by coinciding the aperture stop lever position with the magnification display position corresponding to the magnification of the objective lens to be used.

Numerical aperture of objective lens and numerical aperture of condenser suitable for observation

Objectives	Magnification	Numerical aperture NA	Numerical aperture of condenser suitable for observation of microscope specimens (when setting to 70% of numerical aperture of objective lens)
Plan objective lens (FN 20)	4X	0.10	$0.1 \times 0.7 = 0.07$
	10X	0.25	$0.25 \times 0.7 = 0.175$
	40X	0.65	$0.65 \times 0.7 = 0.455$
CX22PL100XO (option)	100XO	1.25	$1.25 \times 0.7 = 0.875$

# 6 Troubleshooting

Under certain conditions, performance of the microscope may not be given properly. If problems occur, please review the following list and take remedial action as needed.

If you cannot solve the problem after checking the entire list, please contact Olympus for assistance.

Problem	Cause	Remedy	Reference page
1. The brightness of observed field of view is uneven.	The objective is not engaged in the light path.	Engage the objective in the light path by rotating the revolving nosepiece until its clicks.	12
	The condenser is too much lowered.	Raise it to the upper limit.	10
	The objective, eyepiece, condenser and/ or window lens are dirty.	Clean them thoroughly.	4
2. Dust or stains are visible in observed field of view.	The eyepiece, condenser, window lens and/or specimen slide are dirty.	Clean them thoroughly.	4
3. Observation image glares.	The condenser is too much lowered.	Raise it.	10
	The aperture iris diaphragm lever is stopped down excessively.	Adjust the aperture iris diaphragm lever according to the objective magnification to use.	10
4. Observation image is whitish, blurred or unclear.	The objective is not engaged in the light path.	Engage the objective in the light path by rotating the revolving nosepiece until its clicks.	12
	The eyepiece, condenser, window lens and/or specimen slide are dirty.	Clean them thoroughly.	4
	Immersion oil is not used with an oil immersion objective.	Use immersion oil.	13
	Air bubbles are contained in the immersion oil.	Remove the air bubbles.	13
	The designated immersion oil is not used.	Use immersion oil provided by Olympus.	13
5. Part of the image is defocused or the image looks like it's flowing.	The objective is not engaged in the light path.	Engage the objective in the light path by rotating the revolving nosepiece until its clicks.	12
	The specimen slide is not set properly on the stage.	Set the specimen slide correctly on the stage and secure it using the specimen holder	8
6. High magnification objective hits the specimen slide just before the specimen comes into focus.	The specimen slide is set upside down.	Set the specimen slide correctly with the cover glass up.	8
7. Rotation of the coarse adjustment knob is too tight.	The tension adjustment ring is set too tight.	Loosen the tension adjustment ring to get proper tension.	9
8. It is impossible to bring the specimen into focus (because the stage can not be raised).	The pre-focusing knob is positioned too low.	Raise its position.	10

Problem	Cause	Remedy	Reference page
9. The stage descends by its own weight or the focus is lost due to slippage of the coarse adjustment knob.	Tension adjustment ring is set too loose.	Tighten the tension adjustment ring to get proper tension.	9
10. The stage can not be lowered enough.	The condenser is too much lowered.	Raise it.	10
11. Fields of view of two eyes do not coincide.	The interpupillary distance is not adjusted correctly.	Adjust it correctly.	10
	The difference in diopter of two eyes are not compensated.	Compensate it correctly.	11
	Different eyepieces are used between the left side and right side.	Use same eyepiece on the left side and right side.	22
12. Objective hits the specimen slide when it is switched from lower magnification to a higher magnification.	The specimen slide is set upside down.	Set the specimen slide correctly with the cover glass up.	8
	The cover glass is too thick.	Use a cover glass with thickness of 0.17 mm.	8
13. The LED illumination does not light.	The AC adapter or power cord is unplugged.	Plug it securely.	20
14. When changing the magnification, it is defocused significantly.	The diopter is not matched.	Adjust the diopter of the eyepiece correctly.	11

# 7 Specifications

Item	Specification	
Optical system	Infinity correction optical system	
Illumination	Built-in 0.5 W LED illumination system. 5-6 V 0.5 A $\overline{\text{---}}$ (AC adapter:100-240 V 50/60 Hz 0.4 A) Power consumption: 1.7 W	
Focusing mechanism	Stage height adjustment mechanism. Movement distance per scale of fine adjustment knob: 2.5 $\mu\text{m}$ Movement distance per round of fine adjustment knob: 0.3 mm Total movement range: 15 mm Pre-focusing knob provided, tension of the coarse adjustment knob adjustable.	
Revolving nosepiece	4 holes revolving nosepiece (fixed backward).	
Binocular observation tube	Field number	20
	Tube tilting angle	30 °
	Interpupillary distance adjustment range	48 to 87 mm
Stage	Size	120 x 132 mm (with mechanical stage)
	Movement range	X direction: 76 mm x Y direction: 30 mm
	Specimen holder	Holds a single specimen.
Condenser	Type	Abbe condenser
	N. A .	1.25 (when immersed in oil)
	Aperture iris diaphragm	Built in
Dimensions & weight	198 (W) X 258 (D) X 384 (H) mm / approx. 5.8 kg	
Operating environment	<ul style="list-style-type: none"> <li>• Indoor use.</li> <li>• Altitude: Max. 2,000 meters</li> <li>• Ambient temperature: 5 to 40 °C (41 to 104 °F)</li> <li>• Humidity: Max. 80 % (31 °C or less) (without condensation) In case of over 31 °C (88 °F), the humidity in operating environment is decreased linearly through 70 % at 34 °C (93 °F), 60 % at 37 °C (99 °F), to 50 % at 40 °C 104 °F).</li> <li>• Supply voltage fluctuation: <math>\pm 10</math> %</li> <li>• Pollution degree: 2 (in accordance with IEC60664-1)</li> <li>• Installation/Overvoltage category: II (in accordance with IEC60664-1)</li> </ul>	
Transportation/ storage environment	<ul style="list-style-type: none"> <li>• Temperature: Min. -25 °C, Max. 65 °C</li> <li>• Humidity: Min. 0 %, Max. 90 % (without condensation)</li> </ul>	

# 8 Optical characteristics

The following table shows the optical performances of combinations of eyepieces and objectives.  
The figure on the right shows the performances indicated on the objectives.

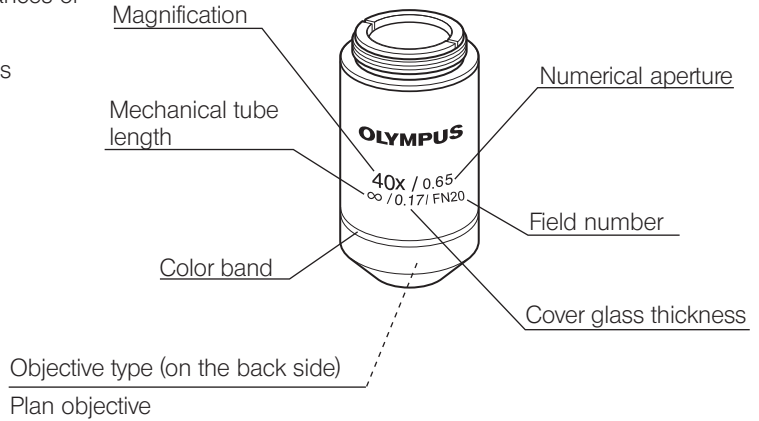

Optical performance Objectives	Magnification	Numerical aperture NA	Working distance W.D. (mm)	Cover glass thickness (mm)	Resolution ( $\mu\text{m}$ )	10X Eyepieces (FN 20)			Remark
						Total magnification	Depth of focus ( $\mu\text{m}$ )	Actual field of view	
Plan objective (FN 20)	4X	0.10	278	-	3.36	40X	175.0	5.0	
	10X	0.25	8.0	-	1.34	100X	28.0	2.0	
	40X	0.65	0.6	0.17	0.52	400X	3.04	0.5	
CX22PL100XO (option)	100XO	1.25	0.13	-	0.27	1000X	0.69	0.2	Oil immersed

Glossary	Meaning
Working distance (WD)	Distance between the top surface of the cover glass and the top of the objective when in focus.
Number of aperture (NA)	This value corresponds to the F-number* of the camera and is related to the resolution. Resolution becomes higher when the NA becomes larger. (*F-number : Value dividing the focal length of the lens by the effective number of aperture. This is used as an index to represent the brightness of the lens.)
Resolution	Ability of an objective for resolving adjacent two points in the image, which is expressed in terms of the minimum distance between two points on the specimen surface.
Focal depth (Object side)	The depth range of a specimen, in which focus is obtained. Stopping down the aperture iris diaphragm increases the depth of focus. The depth of focus is decreased when the NA of objective becomes larger.
Field number (FN)	The diameter of the image observed through an eyepiece, indicated in millimeters.
Actual field of view	Diameter of the field of view, expressed as the size on the specimen surface.
Total power (Total magnification)	Objective magnification x Eyepiece magnification.

# 9 Assembly

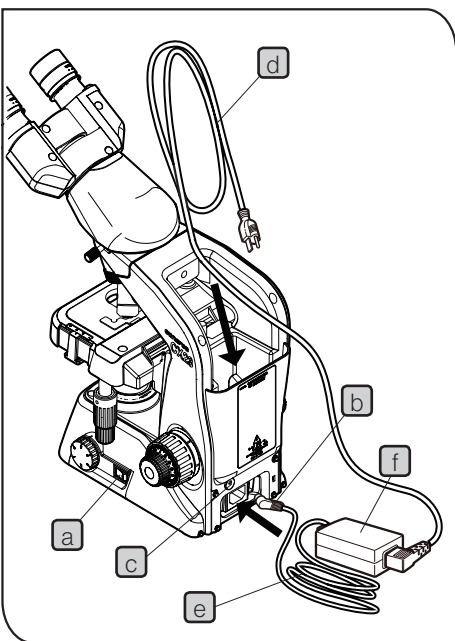
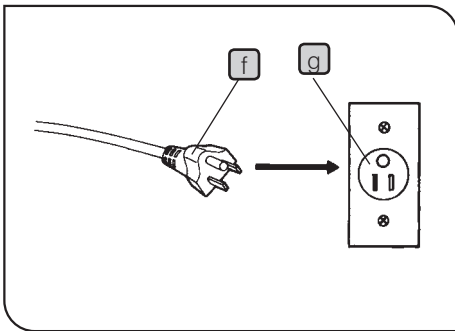
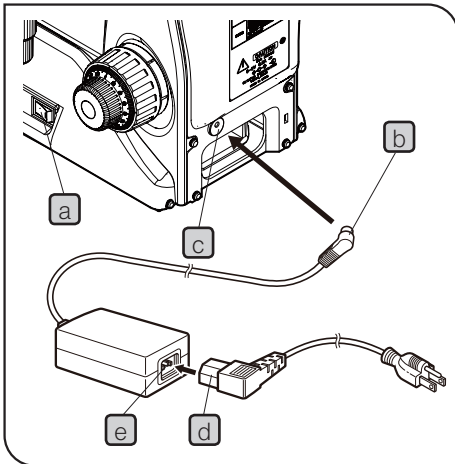

## 1 Connecting the AC adapter and power cord

**CAUTION** • Always use the AC adapter and power cord provided by Olympus. If the proper AC adapter and power cord are not used, the electric safety and EMC performance of the device can not be assured. If no power cord is provided, please select the proper power cord by referring to the section “Proper selection of the power supply cord” at the end of this instruction manual.

• The power cord and AC adapter cord are vulnerable when bent or twisted. Never subject them to excessive force.

• Make sure that the main switch **a** is set to “**○**” (OFF) before connecting the power cord.

- 1 Connect the output connector **b** of the AC adapter to the input connector **c** on the rear of the microscope.

**CAUTION** Do not tilt the microscope to the rear, since doing so could damage the output connector **b**.

- 2 Connect the power cord's connector **d** to connector **e** firmly.
- 3 Connect the power cord's plug **f** to a wall power outlet **g**.

## 2 Storing the AC adapter and power cord

**CAUTION** Make sure that the main switch **a** is set to “**○**” (OFF) before storing the power cord.

- 1 Unplug the power cord's plug from a wall power outlet.
- 2 Disconnect the output connector **b** of the AC adapter from the input connector **c** on the rear of the microscope.
- 3 Bundle the AC adapter cord **e** as shown in the picture on the left, and store it in the space at the bottom of the microscope together with the AC adapter itself **f**. In this case, remove the cable tie attached to the AC adapter cord **e** before storing.
- 4 After the AC adapter cord **e** and the AC adapter **f** are stored, insert the output connector **b** of the AC adapter into the input connector **c**.
- 5 Bundle the power cords **d** and store them on the rear of the microscope.

◎ If you use the kensington lock, insert the AC adapter to the microscope frame upside down.



# 10 Optional accessories

## 10-1 System diagram of optional accessories

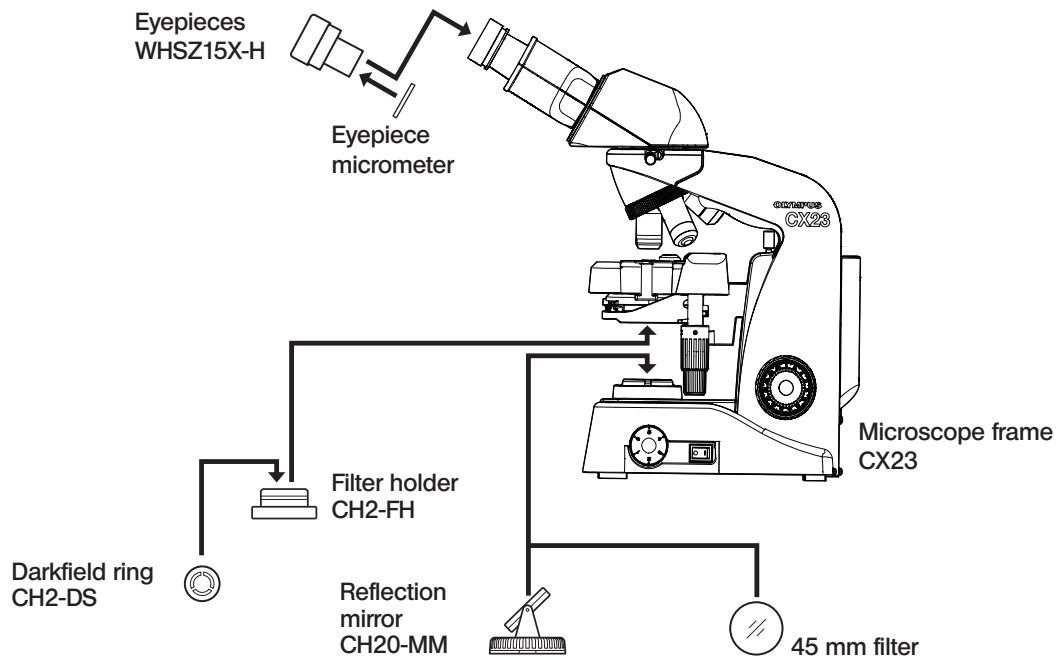

## 10-2 Installation and operation of optional accessories

### 1 Filter holder CH2-FH and darkfield ring CH2-DS

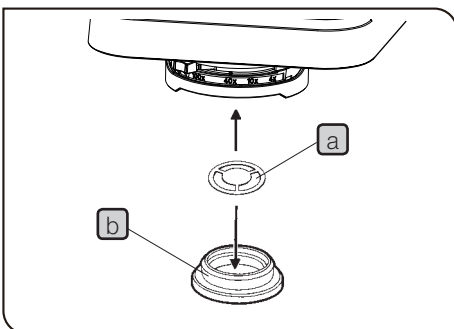

⊙ This holder accommodates the CH2-DS darkfield ring.

- 1 Insert the darkfield ring **a** in the CH2-FH filter holder **b**.
- 2 Push the filter holder **b** containing the darkfield ring **a** into the bottom of the condenser until it clicks into place.

⊙ The darkfield ring enables darkfield observation using an objective from 4X to 40X.

## 2 Eyepieces WHSZ15X-H

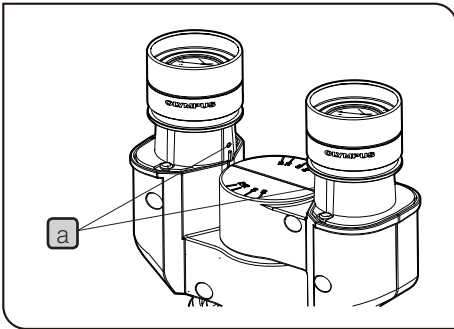

Ⓢ The standard 10X eyepieces are clamped using screws.

- 1 Using a small flat-blade screwdriver, loosen the clamping screws of a 10X eyepiece and remove the eyepiece.
- 2 Insert the WHSZ15 X-H into the eyepiece sleeves and tighten the clamping screws **a**.

## 3 Mounting the eyepiece micrometer (optional)

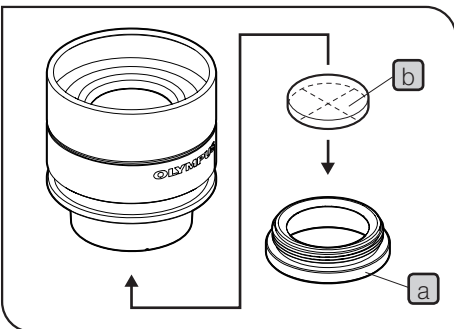

Ⓢ If you are using 10 X eyepiece, please purchase the eyepiece micrometer with a diameter of 24 mm and a thickness of 1.5 mm.

- 1 Loosen the clamping screw of the eyepiece with a small flat-blade screwdriver, and remove the right eyepiece to which the eyepiece micrometer will be attached.
- 2 Hold the eyepiece frame and loosen the reticle holder **a** to remove it.
- 3 Place the micrometer disk **a** into the reticle holder **b** with the indications facing down.

**CAUTION** Be careful not to leave dirt on the micrometer disk, as it will be noticeable during observation.

- 3 Screw the reticle holder **b** containing the micrometer disk **a** into the bottom of an eyepiece. Be sure to screw it in all the way by hooking your nail into the notch **c** on the holder at the end.
- 4 Screw the reticle holder **a** containing the micrometer **b** into the bottom of an eyepiece. Screw in the reticle holder **a** completely until it touches the end.
- 5 Attach the eyepieces to the observation tube, and tighten the clamping screws.

#### 4 Reflection mirror CH20-MM

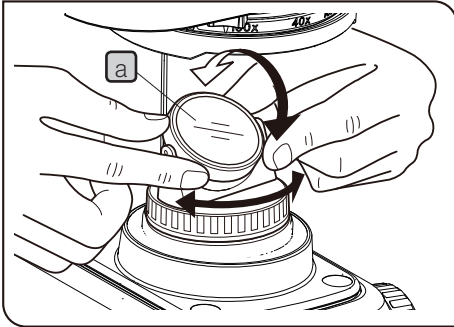

© This is a reflection mirror to be used for microscopic observation using natural light in place of the LED illumination in a location where power supply is not available.

**CAUTION** The microscope should be installed near a window, in a bright place that is not exposed to direct sunlight.

Loosen the observation tube clamping knob and turn the tube by 180°, since the reflection mirror can not catch light if the eyepieces are not oriented toward the rear.

In this case, it is possible to identify the location of the specimen through the hole of the arm.

- 1 Fit the reflection mirror in the window lens of the microscope frame by aligning the position of the mounting tab.
- 2 Face the reflection mirror **a** to the bright light. While looking through the eyepieces, adjust the orientation of the reflection mirror to get brighter field of view.

© A planar reflection mirror is used normally. However, if the brightness of observed field of view is uneven, use a concave reflection mirror.

#### 5 Storing in wooden case (optional)

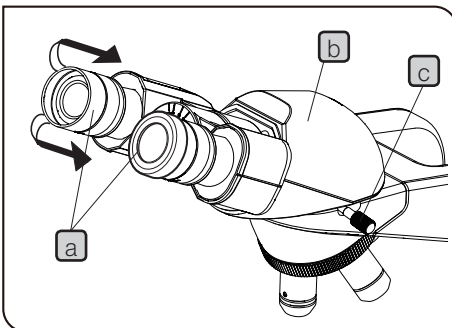

**CAUTION** If the wooden case tilts, the stored CX23 also tilts and it may collide with the case depending on the stage position. When storing this product, be sure to place the stage toward back.

- 1 Store the AC adapter and the power cords into the microscope. For detail, please refer to page 20.
- 2 Fold the eye shades **a** of both eyepieces.
- 3 Hold both eyepieces and fold them downward so that the interpupillary distance becomes minimum.
- 4 Hold the observation tube **b**, and loosen the observation tube clamping knob **c** by turning it counterclockwise (approx. two turns). Then, rotate the observation tube backward and tighten the observation tube clamping knob.
- 5 Pull the plastic ring **d** of the front of the wooden case and open the door.
- 6 Turn the microscope backward and slide it in the wooden case calmly.

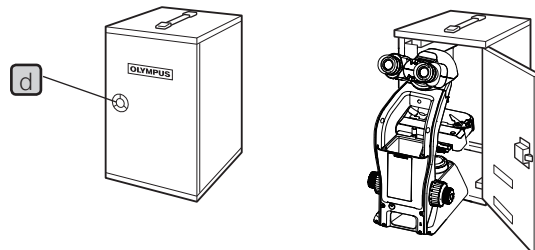

## ■ Proper selection of the power supply cord

If no power supply cord is provided, please select the proper power supply cord for the equipment by referring to “ Specifications ” and “ Certified cord ” below:



















**Caution:** In case you use a non-approved power supply cord for Olympus products, Olympus can no longer warrant the electrical safety of the equipment.

### Specifications

Voltage rating	125 V AC (for 100-120 V AC area) or, 250 V AC (for 220-240 V AC area)
Current rating	6 A minimum
Temperature rating	60 °C minimum
Length	3.05 m maximum
Fittings configuration	Grounding type attachment plug cap. Opposite terminates in molded-on IEC configuration appliance coupling.

**Table 1 Certified cord**

A power supply cord should be certified by one of the agencies listed in Table 1 , or comprised of cordage marked with an agency marking per Table 1 or marked per Table 2. The fittings are to be marked with at least one of the agencies listed in Table 1. In case you are unable to buy locally the power supply cord which is approved by one of the agencies mentioned in Table 1, please use replacements approved by any other equivalent and authorized agencies in your country.

Country	Agency	Certification mark	Country	Agency	Certification mark
Argentina	IRAM		Italy	IMQ	
Australia	SAA		Japan	JET, JQA,	
Austria	ÖVE		Netherlands	KEMA	
Belgium	CEBEC		Norway	NEMKO	
Canada	CSA		Spain	AEE	
Denmark	DEMKO		Sweden	SEMKO	
Finland	FEI		Switzerland	SEV	
France	UTE		United Kingdom	ASTA BSI	
Germany	VDE		U.S.A.	UL	
Ireland	NSAI				

**Table 2 HAR flexible cord**

Approval organizations and cordage harmonization marking methods

Approval organization	Printed or embossed harmonization marking (May be located on jacket or insulation of internal wiring)		Alternative marking utilizing black-red-yellow thread (Length of color section in mm)		
			Black	Red	Yellow
Comite Electrotechnique Belge (CEBEC)	CEBEC	<HAR>	10	30	10
Verband Deutscher Elektrotechniker (VDE) e.V. Prüfstelle	<VDE>	<HAR>	30	10	10
Union Technique de l'Electricite' (UTE)	USE	<HAR>	30	10	30
Instituto Italiano del Marchio di Qualita' (IMQ)	IEMMEQU	<HAR>	10	30	50
British Approvals Service for Electric Cables (BASEC)	BASEC	<HAR>	10	10	30
N.V. KEMA	KEMA-KEUR	<HAR>	10	30	30
SEMKO AB Svenska Elektriska Materielkontrollanstalter	SEMKO	<HAR>	10	10	50
Österreichischer Verband für Elektrotechnik (ÖVE)	<ÖVE>	<HAR>	30	10	50
Danmarks Elektriske Materialkontroll (DEMKO)	<DEMKO>	<HAR>	30	10	30
National Standards Authority of Ireland (NSAI)	<NSAI>	<HAR>	30	30	50
Norges Elektriske Materielkontroll (NEMKO)	NEMKO	<HAR>	10	10	70
Asociacion Electrotecnica Y Electronica Espanola (AEE)	<UNED>	<HAR>	30	10	70
Hellenic Organization for Standardization (ELOT)	ELOT	<HAR>	30	30	70
Instituto Portages da Qualidade (IPQ)	np	<HAR>	10	10	90
Schweizerischer Elektro Technischer Verein (SEV)	SEV	<HAR>	10	30	90
Elektriska Inspektoratet	SETI	<HAR>	10	30	90

Underwriters Laboratories Inc. (UL)  
Canadian Standards Association (CSA)

SV, SVT, SJ or SJT, 3 X 18AWG  
SV, SVT, SJ or SJT, 3 X 18AWG

# MEMO



# OLYMPUS®

[www.olympus.com](http://www.olympus.com)



Manufactured by

**OLYMPUS CORPORATION**

Shinjuku Monolith, 2-3-1 Nishi-Shinjuku, Shinjuku-ku, Tokyo 163-0914, Japan

Distributed by



**OLYMPUS EUROPA SE & CO. KG**

Wendenstrasse 14-18, 20097 Hamburg, Germany

**OLYMPUS SCIENTIFIC SOLUTIONS AMERICAS CORP.**

48 Woerd Avenue Waltham, MA 02453, U.S.A.

**OLYMPUS SINGAPORE PTE LTD.**

491B River Valley Road, #12-01/04 Valley Point Office Tower, Singapore 248373

**OLYMPUS AUSTRALIA PTY. LTD.**

3 Acacia Place, Notting Hill VIC 3168, Australia

**OLYMPUS LATIN AMERICA, INC.**

5301 Blue Lagoon Drive, Suite 290 Miami, FL 33126, U.S.A.

**OLYMPUS KOREA CO., LTD.**

8F Olympus Tower, 446 Bongeunsa-ro, Gangnam-gu, Seoul, Korea 135-509

